

Starting up in Screenprinting

Basic screenprinting consists of a frame onto which a mesh is stretched on one face, hinged to a baseboard, and a flexible squeegee which forces the ink through the clear areas of the mesh and onto the substrate positioned on the baseboard.

Frames can be made from wood, light steel or aluminium and vary in price according to their type and size. A wooden frame is the type most people start with. A 32cm x 42cm frame will print an area of 24cm x 32cm and is an ideal size to begin with.

It is absolutely crucial that the frame should be strong and rigid and the corners fixed at right angles otherwise both the screen and stencil will be unstable, making colour registration when printing impossible. Nowadays a huge range of quality materials is available, frames are readily available from Sericol in wood or metal and, although dearer, a good aluminium frame will give years of service and is less likely to warp or bow.

Covering the Frame with Mesh

Sericol offers a frame covering service through each of its Customer Service Centres. Any frame size or type can be supplied, stretched with mesh of your choice.

As a beginner, if you wish to stretch your own frames, just follow the basic guidelines here.

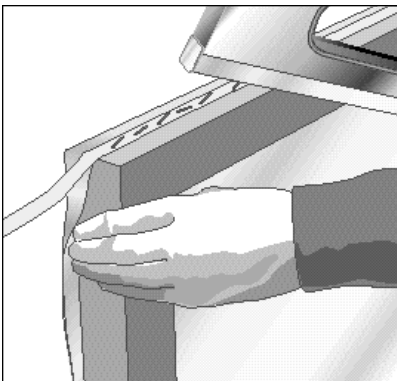

Cut the mesh to size, allowing an approximate 3cm overlap on each side of the frame. When attaching the fabric, staple through a thin strip of card to avoid tearing the mesh.

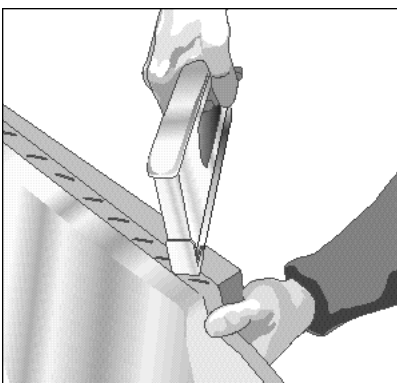

Staple from the centre of one side of the screen towards each corner, pulling the fabric tight as you work. Put the staples at an angle across the side of the frame.

Repeat the process along the opposite side of the frame so that the mesh is tightly stretched across the width of the frame. Secure the other sides in the same way.

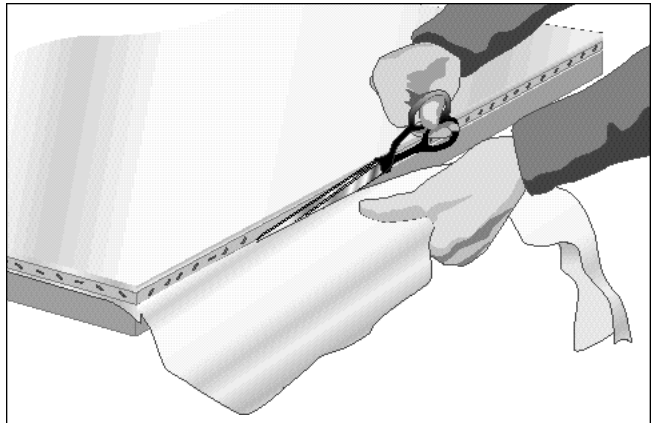

Use scissors or a sharp knife to trim off any surplus mesh around the edges of the frame.

The alternative to stapling the mesh, and now the norm by commercial printers, is to use an adhesive to fix the mesh to the frame. It is particularly important to produce a strong permanent bond between the mesh and the frame, and a variety of special screen mounting adhesives exist. The main groups are reaction adhesives and contact adhesives, both of which employ a catalyst plus a base. 'Serifix' is the Sericol brand name for this type of adhesive and any stretched frames supplied by them would use this method of attaching mesh to frame.

It is often more cost effective to use a trade supplier to stretch your frames, however if you wish to produce your own the following section will give you the basic information to choose the right mesh for your work.

Correct Mesh Selection

Choosing the right mesh to suit a particular job can be just as critical as choosing the right ink. The primary purpose of the mesh is to support the stencil, but beyond that the choice of mesh has considerable influence on print definition, ink usage, and stencil durability.

Sericol are distributors for the Saati range of precision woven screen fabrics. Their entire range is made from synthetic materials, each with its own unique properties and uses.

There are three main types of material currently used by screen printers - monofilament nylon, polyester and, to a lesser extent, multifilament polyester. Because of their different properties, each material has its own particular uses.

Monofilament nylon

Nylon is a strong, flexible and extremely resilient material. But for one failing, it would be an ideal material for screen mesh; it absorbs water and is therefore affected by changes in humidity. Nylon, however, is well suited for printing on uneven surfaces, its high elasticity allows it to deform over irregular surfaces.

Multifilament polyester

In a multifilament polyester mesh, each thread consists of tightly twisted polyester filaments. These tend to have slightly irregular mesh openings and so the final print definition is not as high as with monofilament mesh.

Monofilament polyester

Polyester is considerably more stable than nylon. It is resilient but sufficiently flexible to cope with the normal irregularities of most substrates.

About 80% of all screen printing applications rely on monofilament polyester and the type made by Saati is called Saatilene. It is almost the 'universal' mesh, as it is hardly affected by changes in climatic conditions.

Saatilene Hitech can maintain much higher tensions and has greater dimensional stability than ordinary Saatilene. Hitech comes into its own when very close tolerance printing is called for.

Fabric identification

Saati fabrics are identified by a series of codes in the following way:

Brand name / Mesh count / Thread diameter / Mesh colour / Weave

for example: **Saatilene 140.34UOP** - but what does it mean?

Mesh count

The number following the brand name is the mesh count. This refers to the number of threads per centimetre, e.g. 90, 120, 165 etc..

Thread diameter

Achieving a good stencil relies on keeping the stencil proud of the mesh. Therefore for direct stencils, thinner grades of mesh are preferable. Indirect and capillary stencils can usually achieve this on any grade of mesh, as the film thickness can be selected to suit the mesh.

The number following the mesh count number indicates the thread diameter used to weave the fabric:

120.40 = 40 micron thread diameter
120.34 = 34 micron thread diameter
120.31 = 31 micron thread diameter

These would equate to HD (Heavy Duty), T (Thin Thread Weave) and S (Twill Weave) respectively. There is a trend towards using thinner fabrics with the benefit that the stencil has better edge definition and therefore a higher quality print can be obtained.

Mesh colour

The letter following the thread thickness indicates the mesh colour:

W = White/Undyed fabric
UO = Dyed Ultra Orange fabric

Why should the colour be important? The colour actually has a significant effect on stencil exposure. If a direct stencil is produced on a white fabric, during exposure UV light passing through will be scattered in all directions as it meets the mesh filaments. This leads to undercutting and filling in of fine detail areas and a subsequent poor print quality.

This problem is solved by dyeing the fabric. The colour, ultra-orange, has been carefully selected to absorb around 85 per cent of the UV radiation, rather than reflect or transmit it.

For indirect stencils, such as Autotype's Five-Star, the colour of the mesh is immaterial. Where stencils are produced on the mesh, i.e. emulsions or capillary systems, ultra-orange is recommended. It is worth remembering that when exposing a stencil on dyed mesh, the exposure times must be increased by anything up to 50 per cent.

Fabrics with a mesh count of 62 or finer are readily available dyed ultra-orange; coarser fabrics are usually supplied in white only.

Weave

The letter 'P' following the colour denotes whether the fabric has been woven using special plain weave, e.g. 150.34UOP.

Plaine Weave

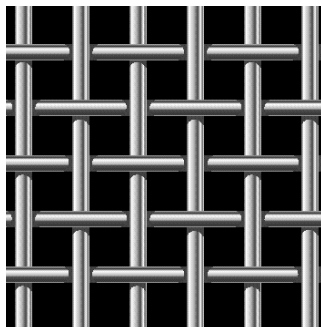

Up to a mesh count of 110, all fabrics are automatically woven as plain weave - one thread over another.

Twill Weave

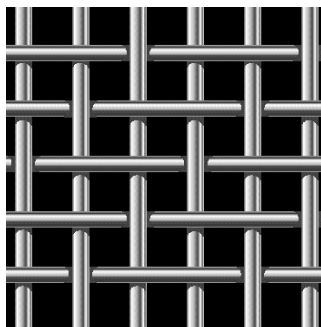

Fabrics from 120 and finer are generally woven as twill weave, one thread over two, or even one thread over three for the very finest.

With advances in weaving technology, it is now possible to produce fabrics up to 150 threads per cm with a 34 micron thread diameter in plain weave.

Plain weave fabric is much thinner than its twill weave counterpart and also has a lower percentage open area. This in turn leads to a lower ink deposit.

A plain weave fabric will produce a high definition print and has the added benefit of significantly reducing the moire effect in four-colour half-tone printing.

Semi-calendered

The letters 'SC' following a mesh colour denote that the mesh has been semi-calendered.

Semi-calendered mesh is produced by flattening the fabric on one side. Semi-calendered has the effect of reducing the thickness and open area of the mesh and therefore its theoretical ink volume.

The volume of ink printed can be further controlled, depending on which way up the mesh is used - whether the calendered side is towards the squeegee or the substrate, with the minimum ink deposit being achieved with the latter.

Treatment of the Screen Mesh

To make durable screens capable of producing high quality images it is important to have a tight, well stretched fabric on the frame and to ensure the mesh is given an appropriate treatment prior to the application of the stencil. Sericol supply a complete range of high quality screen making chemicals designed to prepare and reclaim screens without any damage to the mesh. (See list on page 9). The stretched fabric must be clean before processing. Mesh contains oils which must be removed before a stencil is applied.

There are three distinct stencil types in use currently: Indirect Film, Capillary Direct Film and Direct Emulsions; each of these is different and requires a different treatment technique.

Treatment can essentially be subdivided into three: degreasing and cleaning, abrading, wetting-out the mesh.

Degrease and Clean

A solvent/detergent combination such as Serisolve can be used to combat oils and atmospheric contamination as the screen can be sprayed afterwards with water to disperse, remove and wash away completely such contamination. Ink residues of previous print runs are a major cause of screen soiling, in which case the use of Serisolve is vital. Its solvent/detergent combination absorbs into the ink, making washout far more effective. For extremely difficult stains and residues it may be necessary to use Seripaste, a powerful alkaline cleaning paste, in conjunction with Serisolve.

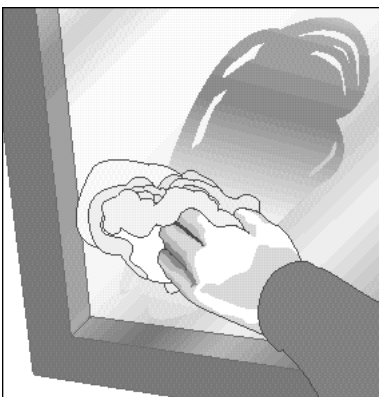

Degreasing the mesh:
The mesh must be conditioned to degrease it and provide a key for the stencil. The type of conditioner used here is rubbed on with a cloth and heat dried.

Abrasion

Indirect film stencils require adhesion to the mesh surface so that the backing film can be easily removed during processing, leaving the gelatine image on the mesh, and they must have good adhesion to the mesh throughout the print run. Adhesion is assisted by gently abrading the mesh to matt its surface and provide a surface into which the stencil can key. Using too coarse an abrasive will result in an over-roughened, weakened mesh and abrasive particles

could become wedged in the mesh openings causing adhesion or printing faults.

Seriprep 101 contains a specially selected fine abrasive in conjunction with a detergent blend to give just the right amount of key.

Wetting

A characteristic of polyester mesh is that even when fully degreased it is naturally hydrophobic, that is, water repellent. Stencils on the other hand are hydrophilic - water attracting.

Abrasion of the mesh does help in this regard but it is far more effective to chemically convert the surface from water repellent to water attracting. Chemical conversion is an important feature of products such as Seriprep 102, Seriprep 300 and Universal Mesh Prep.

Screen Filling

To prevent ink seeping between frame and mesh outside the stencil area, screen filler or tape should be used to seal the inside edges and underside of the frame.

The Squeegee

This is the basic printing tool and consists of a polyurethane blade set in a metal or wooden handle. Various types are available, designed for hand or machine printing. The length of the squeegee is determined by the inside width of the frame, though it should allow for a clearance at both ends of the blade to facilitate a smooth printing action. To maintain a straight 90° printing edge on a squeegee, which is adequate enough for most purposes, grind the blade along a sheet of emery paper using a perpendicular piece of wood as a guide rail.

Stencils

Screen printing is a stencil process and is based on the principle of blocking out areas of mesh in order to prevent ink passing through while leaving clear open areas which do allow ink through. There are two basic types of stencil, direct and indirect. Direct stencils are made on the mesh, while indirect stencils are processed separately and adhered to the mesh at a later stage. The third type is capillary, which is a combination of both types.

Direct Stencils

The most basic direct stencil is a block-out substance on the mesh. To do this, trace the design which you want lightly on to the mesh. The area which you do not wish to print is then blocked out with a screen filler. It can be applied by brush, card or finger, depending on the texture you want. This leaves the open design ready for printing. Make sure the printing ink is the reverse of the type of filler used. For instance, if you used a water-based filler you must use a solvent-based ink. Any pin holes which occur in the blocked-out areas can easily be filled in.

Most commercial printers and those with a mercury vapour lamp will nowadays use a Direct Photostencil Emulsion such as Dirasol® from Sericol.

These are coated directly on to the mesh on the frame, dried and exposed to a light source, with a film positive or other mask to block the light. Once correctly exposed the stencil is washed gently with water and the masked areas washed out to allow ink to pass through the mesh. This type of stencil is very durable and high quality prints on quite long print runs are easily achievable.

Hand Cut Stencils

Indirect stencils are made away from the screen, separate from the mesh.

Hand-cut stencil films are available under different trade names but they all share the common qualities of producing good quality images. Most of them consist of a thin coating of stencil material on a temporary support such as transparent paper or transparent plastic which allows the design to show through, thus facilitating cutting. Peeling is simple and areas removed accidentally are easily replaced. Some types are water-based and these are easily affixed to the screen by wet sponge or soft squeegee. Others employ a mixture of water and methylated spirits, and the third type are attached to the screen by ironing them on.

The method of making the stencils for all types is quite simple. Position the stencil film/paper over the design with its backing sheet underneath. Using a stencil knife, cut away the design from the top layer only. Care must be taken not to cut too heavily as the backing sheet can be dented and this will affect adhesion of the stencil to the mesh. Peel the areas away which you wish to print, using your knife to lift the cut edges. Place the completed stencil on a piece of card slightly smaller than the inside dimensions of the frame. Lay the frame over it, ensuring that the film is in contact with the underside of the mesh and positioned centrally. Using two pads of soft cloth, wet one with the recommended adhering liquid and wipe a small portion with one stroke and dry immediately with the other pad, using a light rubbing motion until all liquid has evaporated. Continue over the whole stencil area, working in one direction only to avoid wrinkling. When the stencil is dry, slowly pull away the backing sheet from the upturned frame.

Making a hand cut stencil.

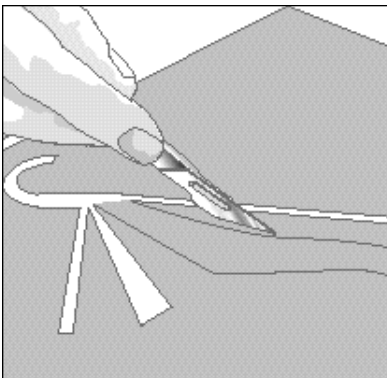

1. Place the stencil film matt side up and cut into the top layer with a scalpel to make the design, leaving the transparent backing film intact.

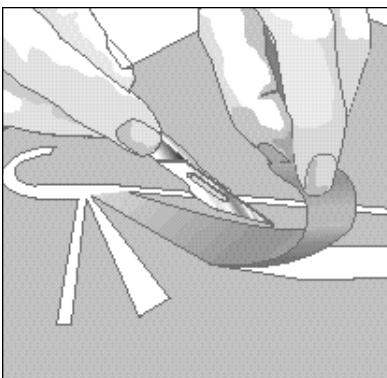

2. Peel away the cut shapes from the backing film, lifting the edges carefully with the scalpel.

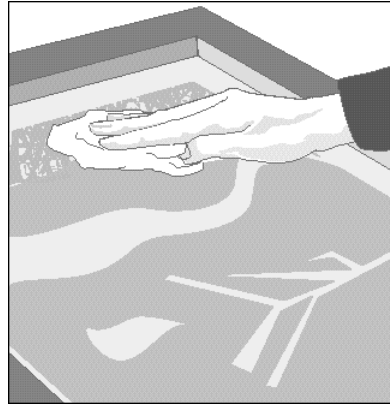

3. Place the stencil on a flat worktop and position the screen over it, printing side down. Dab the mesh with clean damp cotton wool until the stencil adheres completely to the underside of the screen.

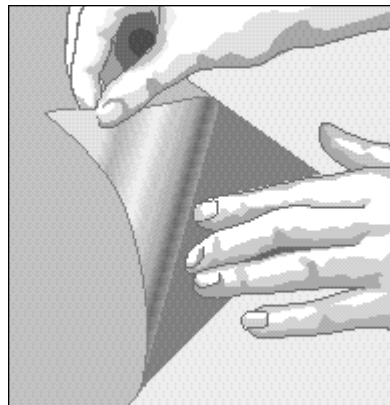

4. Dry the screen thoroughly and then peel away the transparent backing film, leaving the stencil on the screen mesh.

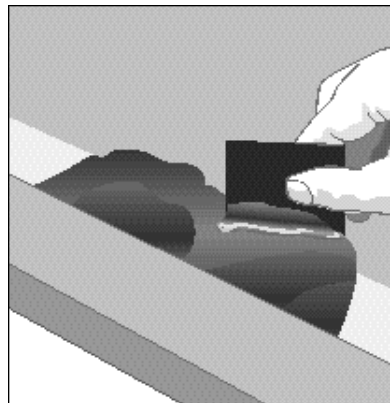

5. Use a piece of card to spread a coating of blue filler over bare areas of fabric around the stencil. When the filler is dry the screen is ready to print.

Photostencils

A photostencil is light sensitive so that exposure to ultraviolet light hardens the surface, causing it to become impervious to either solvent or water. The stencil material is exposed to UV light through a positive. A positive image is one which is literally the opposite of a negative. That is to say, the printing images are opaque rather than transparent. These are carried on a transparent base to allow light through to the parts of the stencil which become hard on final processing. When washed, the soft stencil areas (those which have not been exposed to light because of the opaque image) wash away so that the image is clearly defined. This principle applies to all photostencils whether they are coated directly onto the screen or processed away from the screen and fixed on later. There is a third process, a combination of these two, in which an indirect film is impregnated into the mesh.

Direct Photostencils

The mesh on the frame is coated with the photosensitive emulsion and, after drying, is exposed to a light source through a positive transparency.

The areas of the positive which are opaque and which are to be represented in print protect the emulsion so that it remains soft and can be washed away. Those areas which are exposed to the light are hardened so that they become impervious to ink.

Preparing a direct photostencil

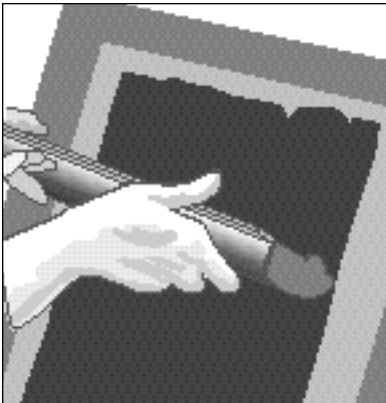

1. Fill a coating trough with light-sensitive emulsion. Draw the trough up the screen at an angle to lay an even coating of emulsion on the mesh.

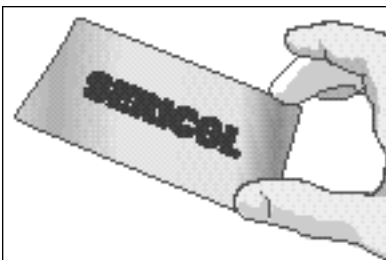

2. Dry off the coated screen in a dark room. Place the photo-positive on the exposure unit with the image reading the right way round as you look at it.

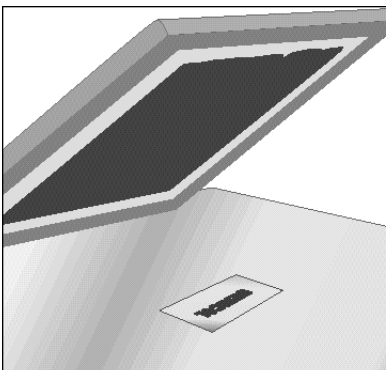

3. Position the light-sensitive screen over the positive. Close the exposure unit and expose the screen to ultraviolet light for the right length of time.

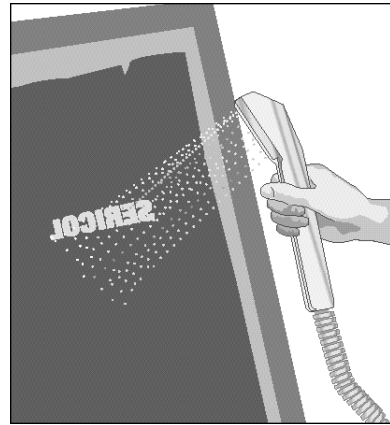

4. After exposure, wash the screen out with water. The emulsion has been hardened by the light but those areas protected by the positive image are washed away.

Indirect Photostencils

Indirect stencils, as mentioned earlier, are made away from the screen and attached to it after exposure and development. They are quick to process and are capable of reproducing fine detail and halftones. Whichever type of indirect stencil used, the technique application remains essentially the same. The stencil is usually in the form of a two-layer film. One layer consists of emulsion, the other layer is a transparent backing sheet which is removed after exposure. The emulsion side of the positive is placed in contact with the backing sheet of the stencil. The stencil film is then exposed to light through the positive, after which it is developed in a solution of hydrogen peroxide. This process of developing further hardens the areas on the stencil which were exposed to UV light. It is worth noting that there are photostencil films such as Novastar from Autotype which require no chemical hardening or hot water wash out.

The stencil is washed to remove the soft areas, the shapes of which are the print area. The screen is then lowered onto the stencil and any excess water removed by blotting with a chamois leather or clean newsprint. Drying can be done with a cool fan. When the stencil is absolutely dry the plastic backing can be peeled away.

Direct/Indirect Method

The advantage of this technique is that the durable quality of direct photostencil emulsion is combined with the accuracy and fine detail of indirect photostencil film.

The method of application is relatively simple. The screen mesh is laid down on top of the stencil film which is itself laid emulsion side up. A transfer medium is then squeezed through the mesh and onto the film. By doing this the mesh is impregnated with the film. With the ordinary indirect method the film is attached only by the drying process. When the transfer medium is dry the backing sheet can be removed and the screen is then ready for exposure. From now on the screen is processed in the same manner as a direct photostencil.

The Printing Table

At its most basic the frame can be hinged to a flat piece of blockboard large enough to hold the material being printed, registration being enabled by sticking tabs to the baseboard to locate the material in the same place for each print.

The Hingebar

There are many suppliers of 'basic entry' screen printing equipment (see list on page 10) but it is also possible to get a reasonable result with a good frame and a pair of hinges screwed to a good flat board and utilising a low tack adhesive to hold the stock to the base board whilst printing.

With a hinged assembly it is important to allow the gap between the bottom of the frame and the baseboard to be adjustable. This will allow printing onto paper of different thicknesses. The best way to allow this is to fix a hingebar, made from the same size wood as the frame, to the baseboard. If you use bolts with wing nuts, adjustment of the hingebar is quite easy. Attach the frame to the hingebar and when doing this use push-pin hinges. The pins can be removed and the frame easily removed for cleaning etc. When printing on card or thick plastic the hingebar can be raised by inserting a block between frame and baseboard.

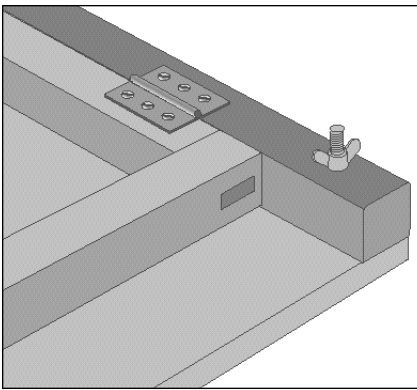

Fix the hingebar to the baseboard. A bolt and wing nut at each end of the bar enable it to be raised if necessary.

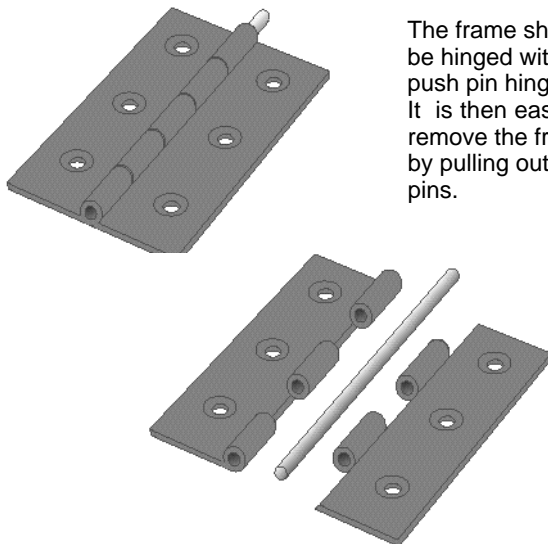

The frame should be hinged with push pin hinges. It is then easy to remove the frame by pulling out the pins.

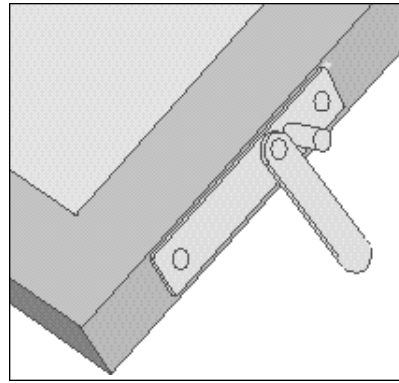

To help in removing a wet print and positioning substrate prior to printing, it is a good idea to make a prop bar for one side of the frame. This can be made from wood or metal about 10cm long, placed on the frame to allow it to stand at 45°.

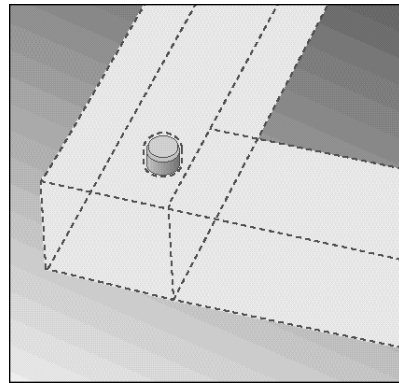

To minimise any lateral movement in the frame and to ensure correct registration, fix a short dowel into the baseboard, protruding about 5mm. Drill a hole in the underside of the frame so that when it is lowered for printing the dowel interlocks.

Printing

Once the stencil is made you are ready to print, and no matter which stencil type has been used there is a basic procedure to follow before printing.

First, check registration. This is the positioning of the screen relative to the substrate on which the image is to be printed. Ideally all stencils should include register marks, (right angled crosses), which should appear on all the screen stencils and positives of all the printing colours for a job. It is imperative that the crosses register perfectly for each new colour. The ability to see through most screen fabrics is an advantage and many print tables in industry employ register systems incorporating precision movement of the vacuum bed and hinging gear. Paper, however, is unstable and despite regular checks during the print run it can be quite difficult to maintain register, particularly if printing of subsequent colours is carried out over several days.

To achieve a clean, sharp print the mesh should not touch the surface of the substrate when the frame is lowered into the printing position but should have a slight clearance to prevent the wet ink from attaching itself to the screen after the squeegee has forced the colour through. This clearance, or 'snap distance', can be achieved by fixing strips of card under the frame, or using the adjustable screws fixed at the corners of the frame for height adjustment.

Check the frame for movement and make sure that the hinge unit has no play in it. Check the edge of the squeegee for dents or nicks. Examine the stencil for pin holes, wear or uneven areas and mesh blockages. Finally, see that your inks are mixed thoroughly and are of the desired shade and consistency.

Before printing a long run it is advisable to pull a few proofs to enable a check of quality and accuracy of colour and register. Any minor adjustments of colour or registration can then be made before you actually begin the print run.

The printing process is relatively simple. Raise the screen and place stock against the registration guides. Then lower the screen on to the baseboard or table. Pour ink into the screen at one end so that it is spread evenly from one side of the frame to the other. Position the squeegee behind the colour and close to the frame. Then, standing at the opposite end, pull at an angle of about 45° towards you, maintaining a constant speed and without altering the angle of the blade. Look for the speed that the mesh snaps away from the print surface following the passage of the squeegee. If the print is slow in releasing the screen mesh, then adjustment must be made to the height of the frame and the squeegee angle altered. As a rough guide, a pull at angles close to horizontal gives a heavy deposit of ink, increasing possibility of the print sticking to the mesh and causing lack of edge definition. A pull at too vertical an angle puts down a very thin, uneven layer of colour and may cause the squeegee to judder.

After the squeegee is pulled down the length of the frame, raise the screen slightly and push the squeegee and ink towards the back of the screen. This will deposit a flood coating of ink which ensures an adequate ink deposit for the next pull. Finally, remove the print and place it in a drying rack.

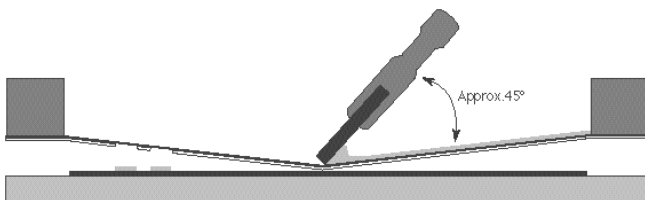

The screen mesh must on no account come into contact with the printing paper when the frame is laid down upon it prior to printing. There should be a gap of about 0.5cm between the mesh and the paper. Generally the only exception to this rule would be when printing fleece fabrics. When you are printing you should pull the squeegee towards you at an angle of about 45°.

The most complex image to print is one which incorporates continuous tones. The only way that this can be done is by breaking the tonal image down into dots, the darker areas of the print being made up of larger dots, and the light areas consisting of smaller dots which allow more of the paper to show through. To achieve this translation from a solid tone to a system of dots, the image which you want to print is usually photographed through a halftone screen in a process camera.

When the process has been completed you will have a positive image on film from which a direct or indirect stencil can be made.

If you want to produce multicoloured images incorporating halftones, you will again have to use a process camera. The camera is able to separate the colours so that halftones are printed through four separate colours of process cyan, magenta, yellow and black which, when overprinted, make a composite four colour picture.

What to avoid



1. Smudging against the edge of the frame or the finger due to the print being lifted carelessly.



2. Flooding on the edge of the print caused by the squeegee angle being too horizontal.



3. Insufficient inking caused by the squeegee being too vertical.



4. A blocked stencil due to gelatine not being properly washed out of the mesh.



5. Offset double image caused by screen being lowered on to the wet print.

Cleaning the Screen

After you have finished printing you must clean the screen. Wear rubber gloves for protection as some solvents can irritate the skin. A piece of card can be used to scoop up any excess ink and replace it in the container. The squeegee should be held in a vertical position above the container and carefully scraped with the card or a spatula, allowing excess ink to be saved. The frame can be detached and cleaned.

White spirit will remove solvent-based inks. Stubborn hardened inks will be easily cleaned by the use of a universal screen wash such as 'Seriwash' supplied by Sericol.

If the screen remains on the baseboard, first place old card or newsprint underneath and rub the inside with wipers impregnated with solvent, replacing newsprint until very little colour is left. Use a clean soaked wiper on the underside of the screen in a counter-movement with the wiper rubbing the inside mesh. Repeat until no trace of colour remains on the wiper. Care must be taken in rubbing the underside, particularly if the stencil is a film rather than direct emulsion, as this is the surface to which the stencil adheres.

Cleaning the screen

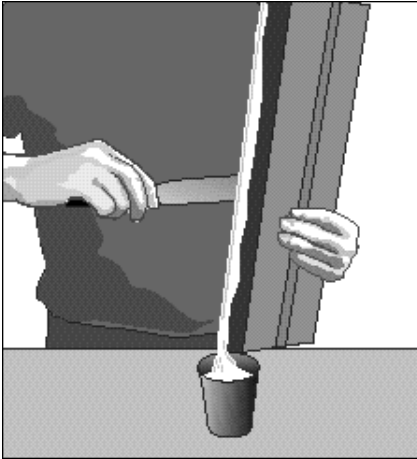

1. Hold the squeegee upright and scrape ink down the blade with a palette knife. Use thinners to wipe the squeegee clean.

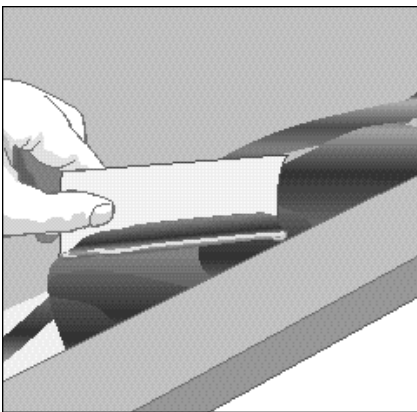

2. Scoop any surplus ink out of the screen with a piece of card.

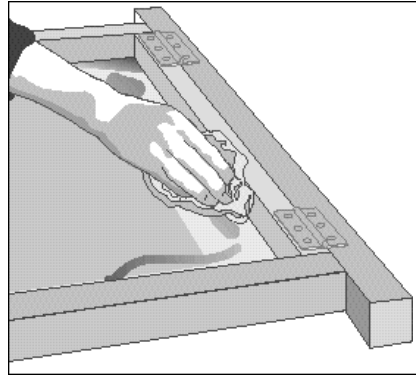

3. Wipe out the inside of screen and mesh with thinners and clean wipers. Rest the screen on sheets of newsprint and work until the mesh is quite clear of ink.

Screen Preparation Products

Serifix®/2 Extra - Screen Mounting Adhesive

An advanced 2-pack screen mounting adhesive for optimum adhesion to all frame types. Combines extended pot life and excellent brushing properties with fast cut out time and resistance to solvents.

Seriprep® 101 - Mesh Preparation Paste

The safe and labour-saving pre-treatment of new mesh for use with indirect stencil films. Combines surface abrasion with degreasing, suitable for all mesh. One treatment only is necessary, use Seriprep 102 before second and subsequent stencils.

Seriprep® 102 - Degreasing and Emulsifying Concentrate

The ideal mesh pre-treatment for direct emulsions, capillary and direct/indirect films, on both new and used screens. Equally suitable with indirect stencil films on screens originally treated with Seriprep 101. Ensures consistent adhesion, eliminates static, fisheyes and pinholes.

Seriprep® 300 - Sprayable Degreasing Concentrate

A water miscible degreaser primarily designed for automatic screen cleaning machines and manual spray application to large screens, but which can also be applied by sponge. Seriprep 300 will effectively remove all greases and similar contaminants from all meshes. On polyester meshes it will in addition impart anti-static properties.

Serifil WR - Water Resistant Screen Filler

A simply applied, solvent soluble screen filler for masking and spotting out water resistant stencils. Highly flexible and durable in use. Can be used with water-based graphic inks when used in conjunction with Serisolve Aqua as a screen cleaner.

Sericure - Stencil Waterproofing Agent

A reliable and fast acting chemical hardener for the production of extra water-resistant stencils.

Dirasol Super Hardener - Post Hardening System

A two-pack chemical system for post hardening all Dirasol emulsions. Post hardening further cross-links the previously exposed emulsion producing stencils which have maximum resistance to solvent and water-based inks, as well as improved abrasion resistance.

Protolac - Edge Protection Lacquer

A two-pack product for permanent protection of the stretched frame. It can also be used either as a stencil mask or as a stencil reinforcer. Incorporates a separate base and hardener, simply mixed in equal quantities, and easily applied using a brush.

Screen Reclaiming Products

Seristrip Powder® - Stencil Decoating Concentrate

A highly effective and economical stencil decoating concentrate that does not react with hard water, thus ensuring that the active ingredients remain fully in solution to attack the stencil.

Seristrip® Gel - Stencil Decoating Concentrate

All the advantages of Seristrip Powder plus a special gelling agent. Fast, economical decoating of large frames.

Seristrip® Liquid - Stencil Decoating Concentrate

A stencil decoating concentrate particularly formulated for use in automatic screen cleaning machines. As a liquid, there are no solid contaminants to block or corrode the machine spray jets and it is easily dilutable with water before use. When diluted 1 to 20 it is equivalent in performance to a 1% Seristrip Powder solution.

Screen Cleaning Products

Serisolve® - Active Screen Cleaner

A unique blend of active solvents with an emulsifying detergent. Removes ink residues prior to stencil decoating and assists in screen reclaiming/cleaning.

Serisolve® HF - Active Screen Cleaner

Applications as Serisolve. Incorporates a carefully selected blend of environmentally safer, cyclohexanone-free, low-odour solvents. Its high flashpoint/low evaporation rate ensures optimum economy in use.

Serisolve® MC - Active Screen Cleaner

Active screen cleaner formulated for rapid and effective removal of all solvent, water-based and UV ink residues in automatic screen cleaning machines. Its high flashpoint/low evaporation rate ensures optimum economy in use.

Serisolve® Aqua

A low solvent-containing water-based screen cleaner designed to rapidly remove water-based graphic inks, without removing Serifil WR screen filler.

Seripaste® - Alkaline Cleaning Paste

The multipurpose cleaner - degreases screen and removes ghost images caused by stencil and ink residues. Degreases and chemically roughens aluminium frames; prepares rotary screens, copper rollers and gravure cylinders.

Universal Stainclean - Alkaline Stain Remover

A one-pack stain remover for the rapid cleaning of ink stains from all types of mesh. Its uniform consistency makes it easy to apply and ensures no separation in the container, thereby guaranteeing optimum performance at all times.

Antistain - Diazo Stain Remover

Diazo stain remover. Can be used to optimise and accelerate the performance of SeriClean in the removal of ink stains. Antistain Ultra is fast acting with a gel structure for non-drip application.

SeriClean - Non-Alkaline Stain Remover (patented)

Non-alkaline product designed to remove all types of ink stain. Combines significant safety advantages and, in combination with Antistain, excellent all-round performance.

To help get started the following chart lists just some of the inks in the Sericol range.
 Sericol produce a full range of solvent-based, water-based, plastisol and UV curing inks - suitable for all applications.

For more details and information on the complete Sericol range please contact your local Sericol Customer Service Centre or the Sericol Technical Helpline whose telephone numbers are on the back of this leaflet.

Paper & Board				Plastic				Textile					
	Coolstar OT High Satin	Seristar SX Gloss	Colorjet CO Matt		Polyplast PY High Gloss	Multijet LO High Gloss	Trichromatic Plastijet TG High Gloss	MatPlast MG Matt		Texiscreen Aqua AJ	Texopaque OP	MultiTran XM	Nylobag NX
Substrates													
Poster papers	●	-	●	PVC	●	●	●	●	100% Cotton	●●●	●●●	●●●	●●●
Coated papers	●	●	●	Polystyrene	-	●	●	●	50/50 Cotton/Polyester	●●●	●●●	●●●	●●●
Boards	●	●	●	Polycarbonate	●	●	-	●	Polyester	●●	●●	●●	●●●*
Wood	-	●	●	Coated paper	●	●	-	●	Acrylic	●●	●●	●●	●●●*
'Polyart'	-	●	-	Acrylic	●	●	-	●	Nylon	●	●	○	●●●*
'Tyvek'	-	-	-	ABS	●	-	-	●					
				CAB	●	-	-	●					
				Fluted polyolefin	-	-	-	-					
				Sheet polypropylene	-	-	-	-					
				Injection moulded polyolefin	-	-	-	-					
Properties													
Drying speed	●●●	●●	●	Drying speed	●●	●●	●●●	●●	Wet-on-Wet Printability	●●●	●●	○	○
Screen stability	●●●	●●●	●●	Screen stability	●●	●●	●●●	●●	Screen Stability	●	●●●	●●●	●
Opacity	●●	●	●●	Opacity	●●	●●	-	●●●	Handle	●●●	●	●●	●
Hold out	●●	●●	●●●	Wetherability	●● (●●●v)	●●	●	●	Flash Cure Speed	●	●●	●●●	●
Rub resistance	●●●	●●	●	Flexability	●●●	●●●	●●	●●●	Cold Cure	Yes*	-	-	Yes
Scuff resistance	●●●	●●●	●	Curll resistance	●●●	●●●	●●	●●●	Wash Resistance	60°C	60°C	60°C	95°C
Curll resistance	●●●	●●	●●●	Alcohol/Petrol res.	●●	○	○	○	Dry Clean Resistance	●●●	○	○	●●●*
									Ironability	●●●	○	○	●●●*
Thinning & Coverage													
Thinning level	30-40%	20-30%	10-20%	Thinning level	15-25%	10-20%	20-30%	10-15%	Thinning level	0-5%	0-5%	0-5%	0-10%
Thinner	ZC-521	ZC-530	ZC-521	Thinner	ZV-557	ZV-552	ZV-551	ZC-521	Flow Thinner	Water	ZE-592	ZE-591	ZE-805
Retarder	ZC-523	ZC-533	ZC-529	Retarder	ZV-558	ZV-553	ZV-553	ZC-533	Cleaner	Water	ZS-640	ZS-640	ZT-639
Fast thinner	ZV-556	ZC-568	-	Fast thinner	ZV-556	ZV-556	ZV-556	ZV-556	Retarder	ZE-592	-	-	ZE-806
Approx. coverage through mesh no.	70-80m2/ltr No.120	60-75m2/ltr No.110	65-75m2/ltr No.110	Approximate coverage through mesh no.	70-80m2/kg No.120	70-80m2/kg No.120	80-95m2/kg No.120	30-35m2/kg No.90	Thickener	ZE-596	-	-	ZE-811
Colour Range													
PANTONE Matching System®*	Yes	Yes	-	PANTONE Matching System®*	Yes	Yes	-	Yes	PANTONE Matching System®*	Yes	Yes	-	-
Seritone Matching System	Yes	Yes	Yes	Seritone Matching System	Yes	Yes	-	Yes	Seritone Matching System	-	-	-	-
Lead free line colours	29	34	26	Lead free line colours	29	14	-	27	Transparents	15	7	-	-
Lead containing alternatives	-	-	5	Lead containing alternatives	6	-	-	4	Opagues	1	-	-	-
Flourescents	-	-	-	Flourescents	-	-	-	-	Extra Opagues	-	24	14	14
Transparents	-	-	-	Transparents	3	-	-	-	Flourescents	5	5	-	-
Metallics	2	-	2	Metallics	2	-	-	2	Opaque Flourescents	-	5	5	5
Trichromatics	-	-	-	Trichromatics	5	-	-	-	Trichromatics	4	4	3	-
				Extra Lightfast (EL)	-	-	4	-	Metallics	2	-	-	-

●●● Outstanding ●● Excellent ● Good ○ Not Recommended * Two Pack System v Polyplast PY EL System (Extra Lightfast)

Stencil Emulsion Troubleshooter

Coating

Problem	Cause	Solution
Pinholes	Dust or dirt on screen or in coating trough.	<ul style="list-style-type: none"> Keep area clean. Degrease with Seriprep 102/300 Replace lid on emulsion when not in use. Keep coating trough clean and covered.
	Air bubbles caused by coating screen too quickly or air stirred into emulsion	<ul style="list-style-type: none"> Slow coating stroke to ease friction between coating trough lip and mesh. If stirred, allow enough time for bubbles to dispel.
	Emulsion coating too thin for mesh mesh count.	<ul style="list-style-type: none"> Re-evaluate coating thickness, add another coat of emulsion
Fish-eyes	Grease and oils left in mesh due to poor degreasing.	<ul style="list-style-type: none"> Use Seriprep 102 or 300 and rinse thoroughly.
	Chemistry in wash-out tank splashing back onto screen.	<ul style="list-style-type: none"> Rinse well with water after degreasing. Decrease water pressure.
Streaks or lines in coated screens	Damage to coating trough.	<ul style="list-style-type: none"> Use another coating trough. Do not use sandpaper. It will create an uneven edge.
	Condensation in emulsion container.	<ul style="list-style-type: none"> Stir emulsion gently before use do not mix-in air bubbles.
	Old image in screen.	<ul style="list-style-type: none"> Use Antistain and Sericlean. Re-stretch screen with new mesh.
Uneven coating	Improperly tensioned screen.	<ul style="list-style-type: none"> Use screens that are tensioned properly.
	Uneven coating trough.	<ul style="list-style-type: none"> Replace coating trough.
	Coating trough too large for screen.	<ul style="list-style-type: none"> Use correct size coating trough allowing at least 4cm clearance on each side of screen.
Emulsion grainy or lumpy	Emulsion was frozen.	<ul style="list-style-type: none"> Store as directed in the product information sheet.

Inspection

Problem	Cause	Solution
Poor resolution (loss of fine detail)	Exposure lamp too close to the stencil.	<ul style="list-style-type: none"> Lamp should be distanced a minimum of 1 times the diagonal measurement of the coated area.
	Emulsion not suitable for fine detail.	<ul style="list-style-type: none"> Select an emulsion suited to your requirements.
	Poor contact between the screen and film positive.	<ul style="list-style-type: none"> Check vacuum contact.
	White mesh causing 'light scatter'.	<ul style="list-style-type: none"> Use dyed mesh.
	Incorrect mesh selection with respect to artwork.	<ul style="list-style-type: none"> Re-evaluate mesh count and its ability to reproduce your artwork.
	Incorrect emulsion thickness with respect to artwork.	<ul style="list-style-type: none"> Adjust emulsion thickness.
	Over-exposure.	<ul style="list-style-type: none"> Adjust exposure time (use exposure calculator).
	Positive not dense enough.	<ul style="list-style-type: none"> Re-evaluate film processing.
	Insufficient washout causing unexposed emulsion to remain in image area (scumming).	<ul style="list-style-type: none"> Ensure adequate washout after exposure.
	Light source inadequate for artwork requirements.	<ul style="list-style-type: none"> Upgrade to single light source.
	Inadequate emulsion thickness.	<ul style="list-style-type: none"> Increase emulsion coating, use higher solids emulsion.
	Poor contact between the screen and film positive.	<ul style="list-style-type: none"> Check vacuum contact.
	White mesh causing 'light scatter'.	<ul style="list-style-type: none"> Use dyed mesh.
	Light source inadequate for artwork requirements.	<ul style="list-style-type: none"> Upgrade to single lightsource.
Under-exposure.	<ul style="list-style-type: none"> Re-evaluate exposure time to fully harden stencil. 	
Poor definition (lack of edge sharpness)	Inadequate emulsion thickness.	
	Poor contact between the screen and film positive.	
	White mesh causing 'light scatter'.	
	Light source inadequate for artwork requirements.	
Under-exposure.		

Reclaiming

Problem	Cause	Solution
Stencil difficult to reclaim	Solvents will 'lock up' an under-exposed screen.	<ul style="list-style-type: none"> Fully expose screens.
	Use of oily solvent.	<ul style="list-style-type: none"> Degrease screen prior to reclaiming.
	Aggressive solvent used on water resistant stencil.	<ul style="list-style-type: none"> Do not use aggressive solvent (lacquer thinner, vinyl wash) on water resistant stencil.

Exposure & Washout

Problem	Cause	Solution
Coated screen sticking to positives and vacuum frame	Excessive heat on vacuum glass frame.	<ul style="list-style-type: none"> • Check cooling system.
	Insufficient drying of emulsion/high humidity.	<ul style="list-style-type: none"> • Allow coated screen to dry thoroughly. • In drying stage, increase air circulation, use a dehumidifier, heat screen drying area.
Stencil breakdown. Pinholes, delaminations etc	Improper degreasing.	<ul style="list-style-type: none"> • Use Seriprep 102 or 300 and rinse thoroughly.
	Under-exposure.	<ul style="list-style-type: none"> • Re-evaluate exposure time to fully harden stencil. • Check lamp age, type and brand.
	Improper wash out.	<ul style="list-style-type: none"> • Water too warm (do not exceed 40°C). • Decrease water pressure.
	Uneven coating.	<ul style="list-style-type: none"> • Use properly tensioned screen. • Make sure coating trough is straight and even.
	Incorrect coating with respect to mesh count.	<ul style="list-style-type: none"> • Re-evaluate coating thickness.
	Improper mixing of Diazo in diazo or dual cure emulsions.	<ul style="list-style-type: none"> • Mix thoroughly.
	Emulsion's shelf life has been exceeded.	<ul style="list-style-type: none"> • Date when sensitised - store as directed in the product information sheet.
	Emulsions not dry before exposure.	<ul style="list-style-type: none"> • Allow screen to dry thoroughly before exposure. • Control humidity in screen room by using drying box and/or dehumidifier.
	Dirt or dust accumulated on coating during drying.	<ul style="list-style-type: none"> • Keep drying area as clean and as dust free as possible.
Image area difficult to wash out	Over-exposure.	<ul style="list-style-type: none"> • Adjust exposure time (use an exposure calculator).
	Stencil pre-exposed to excessive UV light.	<ul style="list-style-type: none"> • Use safelight in drying and pre-exposure areas. • Check for light leakage.
	Positives not dense enough.	<ul style="list-style-type: none"> • Re-evaluate film processing.
	Coated screens subjected to excessive heat (diazo types).	<ul style="list-style-type: none"> • Do not dry at temperatures exceeding 35°C.
	Poor contact between the screen and film positive.	<ul style="list-style-type: none"> • Check vacuum contact.
	White mesh causing 'light scatter'.	<ul style="list-style-type: none"> • Use dyed mesh.

On Press

Problem	Cause	Solution
Stencil breakdown (pinholes)	See Stencil Break Down/Exposure And Washout.	
	Incorrect emulsion for ink chemistry and/or screen wash.	<ul style="list-style-type: none"> • Use compatible ink and stencil systems.
	Excessive squeegee pressure.	<ul style="list-style-type: none"> • Evaluate conditions which require excessive squeegee pressure and rectify eg. thin the ink, use properly tensioned screens, lower the off-contact, sharpen squeegee.
Brittle Stencil	Low humidity.	<ul style="list-style-type: none"> • Control humidity in print shop.
'Open' areas in stencil not printing	Insufficient washout causing unexposed emulsion to remain in image area (scumming).	<ul style="list-style-type: none"> • Ensure adequate washout after exposure.
	Positives not dense enough.	<ul style="list-style-type: none"> • Re-evaluate film processing.

The information and recommendations contained in this Product Information sheet, as well as technical advice otherwise given by representatives of our Company, whether verbally or in writing, are based on our present knowledge and believed to be accurate. However, no guarantee regarding their accuracy is given as we cannot cover or anticipate every possible application of our products and because manufacturing methods, printing stocks and other materials vary. For the same reason our products are sold without warranty and on condition that users shall make their own tests to satisfy themselves that they will meet fully their particular requirements. Our policy of continuous product improvement might make some of the information contained in this Product Information sheet out of date and users are requested to ensure that they follow current recommendations.

SERICOL
More than ink... Solutions.



Sericol Limited, Pypens Road, Broadstairs, Kent CT10 2LE, England
Telephone: (01843) 866668 Fax: (01843) 872074

UK Sales
Tel: (020) 83918010
Fax: (020) 83918008

Technical Helpline
Tel: 0845 7708070

www.sericol.com

Customer Service Centres
Birmingham: (0121) 327 6808
Bristol: (0117) 251 8171
Broadstairs: (01843) 872178
Gatshhead: (0191) 487 4414
Glasgow: (0141) 429 3919

Leeds: (0113) 244 2277
London-North: (01992) 752800
London-South: (020) 8391 5533
Warrington: (01925) 659788

Export Sales
Pypens Road, Broadstairs
Kent CT10 2LE, England
Tel: +44 (0) 1843 866668
Fax: +44 (0) 1843 872122